

# Can seamer-/ can closing machine **BROWI I**



Machine for closing cans for the  
preservation of food.



## Construction BROWI I

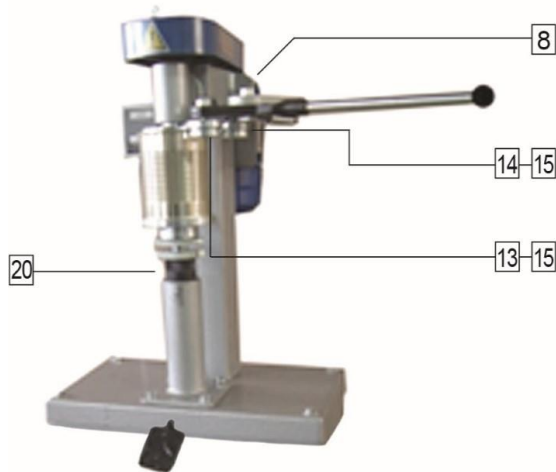
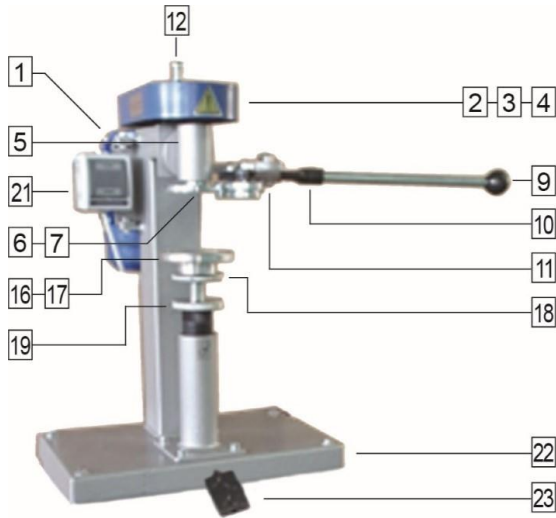

- |    |                                       |
|----|---------------------------------------|
| 1  | Transfer                              |
| 2  | Drive belt                            |
| 3  | Cover                                 |
| 4  | Case                                  |
| 5  | Drive shaft                           |
| 6  | Allen screw M 10X20                   |
| 7  | Closing head                          |
| 8  | Driving engine                        |
| 9  | Folding lever                         |
| 10 | Lever mount                           |
| 11 | Locking screw                         |
| 12 | Shaft blocker                         |
| 13 | Transport roller 1                    |
| 14 | Transport roller 2                    |
| 15 | Way bridge                            |
| 16 | Pad for stackable cans                |
| 17 | Lower idler plate                     |
| 18 | Adjusting wheel                       |
| 19 | Knurl for counterung                  |
| 20 | Quill Adjustment / Pressure Indicator |
| 21 | Engine switch                         |
| 22 | Case / stand                          |
| 23 | Hand lever clamping actuation         |

## Overview

Construction of the BROWI I	Page 02
overview	Page 03
Foreword	Page 03
<b>SAFETY</b>	Page 04
Safety instructions	Page 04
General Description	Page 05
Maintenance / Spare parts	Page 05
Scope of delivery / optional accessory	Page 05
<b>TECHNICAL SPECIFICATIONS</b>	Page 05
COMMISSIONING	page 06
FUNCTIONING	Page 06
SETTING THE PRELOAD	Page 06
SETTING THE LOCKING ROLLERS	Page 06
<b>FOLD IMAGES</b>	Page 07
FORMAT CHANGE	Page 08
CLEANING	Page 08
STORAGE	Page 08
LIABILITY /WARRANTY	Page 08
DECLARATION	Page 08
CONTACT DETAILS	Page 08

## Foreword

This operating manual is intended for users of the BROWI capping / can closure machines as well as for the operating and maintenance person. The manual is not a substitute for a correct introduction to the commissioning and operation of the machine. All persons who involved in commissioning, operation, assembly, maintenance and/or repair during the user's operation must have read and understood these operating instructions in full. The operating instructions, accessible to the personnel, must be set up in the immediate vicinity of the machine preserve. Operate the can closure machine according to the handling instructions in these instructions. If you have any questions, please contact HGB machines and devices.

## SAFETY

### SAFETY INSTRUCTIONS

#### Basics for the construction of the machine:

The machine is built according to the state of the art and the safety regulations. The machine is reliable when used as intended. Nevertheless, improper use may result in dangers for persons or property damage. Avoid any safety-related way of working and pay particular attention to the safety. That is what we are against.

#### Permitted modes of operation

The machine is used exclusively for sealing (flanging) round sheet metal, aluminium or combined cans determined.

#### Prohibited modes of operation:

Any other or further use shall be deemed not to be in accordance with the intended purpose and shall not be permitted.

In particular, the operation of the machine is not permitted:

- with hazardous substances which in any way have harmful effects on the health of persons or the environment,
- with inadmissible changes to the machine.

#### Installed safety devices:

The machine is equipped with a corresponding safety switch.

#### Protective equipment:

The following equipment are to be used when working on the machine:

- Protective clothing
- Protective gloves
- Protective shoes.

#### Technical requirements:

You may operate the machinery only if all safety and protective devices are functional are capable. Check this before each start of work!

#### Operation:

When you setting up and fastening, pay attention to a non-slip surface, which in particular which is free of fat and oils.

Always keep the machine and the work area clean. This is especially important for the handles.

#### Behavior in case of disturbances:

Stop the machine until the fault or damage has been repaired.

Pull out the power plug! Let faults eliminated immediately.



#### Electrical energy:

Work on electrical equipment may only be carried out by electrician be led.

## GENERAL DISCRPTION



### Injury!

During the operation of the machine, there is an increased risk of injury due to moving Masses, hot components and electric current.

The machine was specially designed and built for sealing (flanging) round sheet metal, aluminium or combination cans. It is subject to the provisions of the EG- Machinery- Directives. The machine is largely protected against moisture, observe the care instructions - especially for the sealing rollers. Easy handling of the adjustment or closing rollers and the change of the capping head ensures a fast format change. The machine is supplied with a universal saucer, so that different cans can be processed with a saucer. For the sealing of two-piece cans, aluminium cans as well as for combination cans, a special Lower plate or intermediate plate required. The height adjustment is done via the adjustable quill.

## MAINTENANCE / SPARE PARTS

Clean the machine after each use. Then oil the flow rollers. Use only original spare parts from the manufacturer. Parts and installation instructions are available from manufacturer.

## SCOPE OF DELEVERY / OPTIONAL ACCESSORIES

Compare the scope of delivery with the delivery note and the order documents. Missing parts and damage due to defective packaging or transport should be noted immediately in writing to the freight forwarder and the supplier. The manufacturer/supplier is not liable for subsequent notifications of defects. The machine is secured and packed for transport according to the requirements in order to prevent damage. The machine is delivered in a partially dismantled condition for better transport and to avoid transport damage. Available optional accessories:

- Different capping heads adapted to the can shapes
- Various saucers
- Can test pump
- Food lubricant.

## TECHNICAL SPECIFICATIONS

### ENERGY SUPPLY

Nominal voltage	220 Volt
Frequency	50 Hz
Overall performance	0.55 kW

### SPREADING

Output	max. 500 Cans/h
Format diameter	73-113mm
height cans	min. 20 to max. 119 mm

Rotation speed	1400 rpm.
weight (complete)	37 kg

(Other formats on request)

Sound level measurement 65 dB (A)

Dimensions (w x d x h)	55 x 46 x 60 cm
------------------------	-----------------

(1,5 m distance to the machine)

## COMMISSIONING

Make sure the on/off switch is set to Off. Plug in the power plug.

If everything is set as described in this manual, you can start working. The direction of rotation is determined by the single-phase motor.

## FUNCTIONING

The filled can with the lid attached is placed on the saucer after pressing the clamping lever. The lever, which is equipped with the appropriate preload, is relaxed and holds the can with lid locked into place in the capping head.

The machine is switched on, the locking lever in position 1 flanges the can and into position 2 smooth the fold.

The can is closed. The machine can be switched off and the finished can can be removed by clamping the lever.

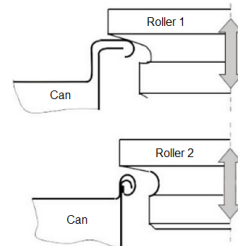

## SETTING THE PRELOAD

If there are markings on the machine, use them to set the tension.

This should be about 60 kg.

For machines without this marking, proceed as follows.

They put the can to be closed with a lid into the device.

Turn down the threaded rod (quill) until the lid touches the capping head.

Now move the preload lever down by 10 mm, hold it in position and turn the quill back against the capping head.

If you now release the preload lever, this corresponds to the required preload force.

Now set this setting by countering the knurled nut of the quill.

In this position, they can now process all cans of the same height.

If the setting height changes, repeat the adjustment process with the changed can height.

## ADJUSTMENT OF THE SEALING ROLLERS

The closure is created by two locking rollers. The "roll" rolls up the edge of the lid like a bead with the edge of the can. The "finished roll" then presses the fold flat on the cans. For the correct adjustment of the sealing rollers to the capping head, the sheet thickness of the cans and lids, the material of the fuselage (sheet, aluminum or cardboard), the edge width of the lids as well as the type and thickness of the rubber coating are decisive. Therefore, it is not possible to specify a specific measure of the distance between the sealing rollers and the capping head.

The exact measure of the distance between the locking rollers and the capping head can only be determined by means of sample closures can be determined.

After the exact measure has been determined, which happens with different strong tongues of a feeling theory, it is advisable to record these measures for later settings in a list / table. We therefore recommend that you carry out a test closure before starting production and, if necessary, correct the setting.

# FOLD IMAGES

## Pre-roll-cut opposite the cross seam



normal



loose



narrow

## Effect of different capping roller settings Cut opposite the cross seam



Roller 1: normal  
Roller 2: normal

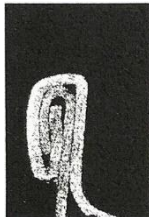

Roller 1: normal  
Roller 2: too loose



Roller 1: normal  
Roller 2: too narrow

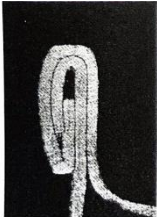

Roller 1: too loose  
Roller 2: normal



Roller 1: too loose  
Roller 2: too loose

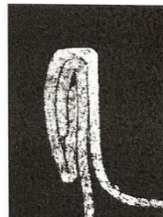

Roller 1: too loose  
Roller 2: too narrow



Roller 1: too narrow  
Roller 2: normal



Roller 1: too narrow  
Roller 2: too loose

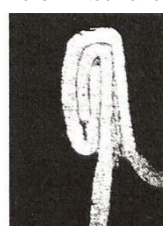

Roller 1: too narrow  
Roller 2: too narrow

## FORMAT CHANGE

For this purpose, the capping head and, if necessary, the lower plate must be changed. In case of questions contact the manufacturer's customer service.

## CLEANING

Only approved for the food sector. Use detergents and lubricants! Aggressive, solvent-based or combustible detergents are not allowed to be used.

## STORAGE

In order to protect a machine that has not been used for a long time, the following should be observed. The storage room must be dry and clean. The machine, in particular the sealing rollers, should be oiled. The machine should be protected from dirt and dust and has to be stored covered.

## DECLARATION OF CONFIRMATION

### Declaration of conformity/ manufacturer's certificate

#### CE-Declaration of conformity

In the sense of the EG-Machine - directives 89/392/EWG, appendix IIA  
We hereby declare,

**Maschinen- und Geräte  
Dipl. Ing (FH) H.G. Broweleit**  
Am Ring 23  
29413 Wallstawe OT Gieseritz  
Tel. +49 39033 967230  
Fax +49 39033 967237  
Germany

that the following machine in its conception and type as well as in the design placed on the market by us complies with the essential health and safety requirements of the EG directives on machinery.

***Due to changes not agreed with us, this declaration loses its validity.***

Designation: **Can seamer- can closing machine**  
Type: **BROWI I**  
Serial number: will not be awarded  
Year of construction: 2018

Relevant EG-Guidelines: 89/392/EWG (Machine - directives)  
modified by 91/396/EWG,93/44/EWG,93/68/EWG

Harmonised standards applied

EN 292-1
EN 292-2
EN 349
EN 60204 (VDE 0113)

Gieseritz, 01.08.2018

Dipl.-Ing. H.-G. Broweleit  
**Maschine u. Geräte**  
Dipl.-Ing. (FH) Hageleit  
29413 Wallstawe OT Gieseritz  
Tel. +49 39033 967230 Fax +49 39033 967237

## LIABILITY / WARRANTY

The manufacturer/supplier assumes no liability or warranty for corrosion damage caused by improper storage. The warranty is based on the contractually stipulated conditions. In the case of unauthorized modifications to the machine, without the written permission of the manufacturer, the liability, warranty and warranty claim expires. This is also the case if the instructions in the operating instructions are not followed. Make sure that only professionals who have read and understood the instruction manual operate the machine. Observe the generally applicable legal and other binding regulations for accident prevention and environmental protection and instruct their observance.

## MASCHINEN UND GERÄTE DIPL.-ING (FH) H.-G. BROWELEIT

Am Ring 23  
29413 Wallstawe, OT Gieseritz  
Germany

phone: +49 39033 967 230  
Fax: +49 39033 967 237

Website: [www.wild-bergehilfe.com](http://www.wild-bergehilfe.com)  
Web-shop: [www.bergehilfe.com](http://www.bergehilfe.com)  
Mail: [info@bergehilfe.com](mailto:info@bergehilfe.com)